



## Sharpak 120 'plus' sharps container with **VisiLOCK™** PATENTED

The Sharpak® 120 'PLUS' was developed following many hours of customer and market research as well as over fifteen years experience gained in the market supplying infection control products to the healthcare sector.

The SHARPAK 120 'PLUS' is approved to the British Standard BS7320:1990 and French Standard NF X 30-500 and tested and certified in accordance with the provisions of the United Nations recommendations on the Transportation of Dangerous Goods, Chapter 9, UN3291 Clinical Waste, Unspecified, NOS.

The SHARPAK 120 'PLUS' offers the following features:

---

MANUFACTURED, TESTED AND CERTIFIED TO BS7320:1990 AND NF X 30-500

---

UN TESTED AND CERTIFIED

---

QUICK AND EASY TO ASSEMBLE

---

EASY TO OPERATE ROTATING OPEN/ CLOSE/LOCK CLOSURE

---

SECURE CLOSURE LOCK

---

FEATURING VISILOCK INDICATOR SYSTEM

---

DISTINCTIVE COLOURING AND CLEAR LABELLING

---

ONE PIECE BASE AND HANDLE MOULDING

---

TOUGH AND DURABLE

---

SEQUENTIAL NUMBERING FOR TRACEABILITY

---

COST EFFECTIVE

---

PURPOSE DESIGNED BRACKET FEATURE FOR SIMPLE WALL AND TROLLEY MOUNTING



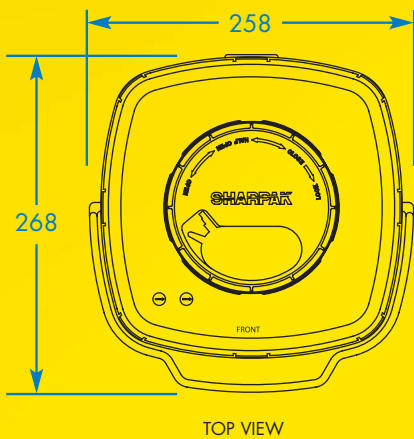

TOP VIEW

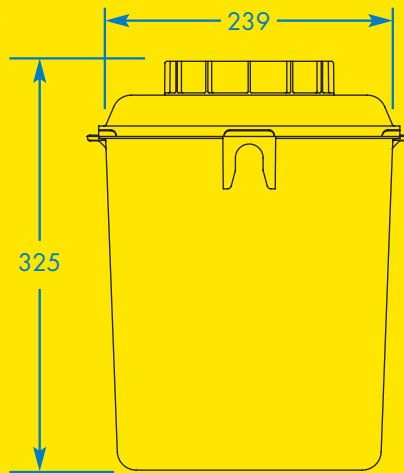

BACK VIEW

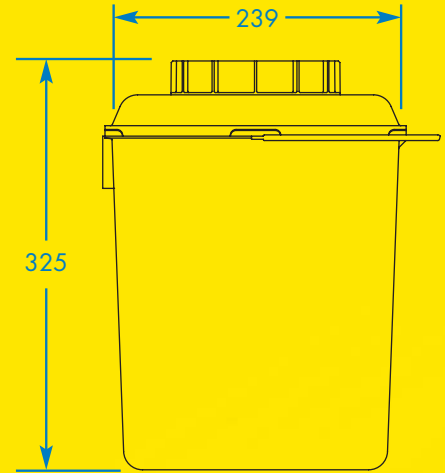

SIDE VIEW

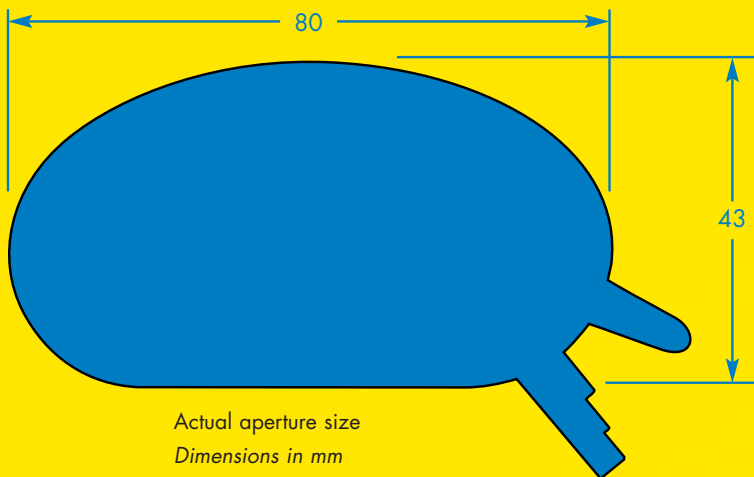

Actual aperture size  
Dimensions in mm

**SHARPAK® 120 'PLUS' INFORMATION**

Height	325 mm
Width	239 mm
Aperture	80 x 43 mm
Max Capacity	12 litres
Capacity to fill line	9.6 litres
SHARPAK 120 PLUS case re-order code	SU02200
Quantity per case	15



OPEN



1ST POSITION 'HALF OPEN'



2ND POSITION 'CLOSED'



3RD POSITION 'LOCKED'  
WITH VISILOCK INDICATOR

For details regarding SHARPAK distributors and world wide availability, please contact: Amcor Flexibles/SPS Laboratoires  
Winterbourne Road Stoke Gifford BRISTOL BS34 6PT  
Tel +44 (0)117 983 6003  
Fax +44 (0)117 983 6001  
E mail david.scarrow@amcor-flexibles.com  
www.sharpakforsharps.co.uk