



Sharpak 60 'plus' sharps container with **VisiLOCK™** PATENTED

The SHARPAK® 60 'PLUS' was developed following many hours of customer and market research as well as over fifteen years experience gained in the market supplying infection control products to the healthcare sector.

The SHARPAK 60 'PLUS' is approved to the British Standard BS7320:1990, French Standard NF X 30-500 and tested and certified in accordance with the provisions of the United Nations recommendations on the Transportation of Dangerous Goods, Chapter 9, UN3291 Clinical Waste, Unspecified, NOS.

The SHARPAK 60 'PLUS' offers the following features:

MANUFACTURING AND TESTED TO BS7320:1990 AND NF X 30-500

UN TESTED AND CERTIFIED

QUICK AND EASY TO ASSEMBLE

EASY TO OPERATE ROTATING OPEN/CLOSE/LOCK CLOSURE

SECURE CLOSURE LOCK

FEATURING VISILOCK INDICATOR SYSTEM

DISTINCTIVE COLOURING AND CLEAR LABELLING

ONE PIECE BASE AND HANDLE MOULDING

TOUGH AND DURABLE

SEQUENTIAL NUMBERING FOR TRACEABILITY

COST EFFECTIVE

PURPOSE DESIGNED BRACKET FEATURE FOR SIMPLE WALL AND TROLLEY MOUNTING



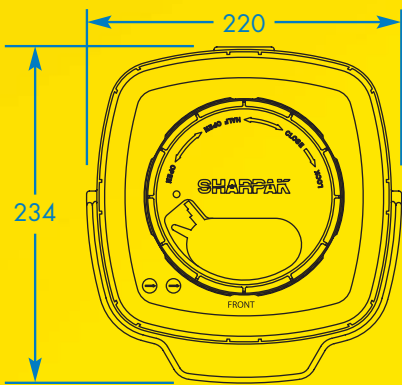

TOP VIEW

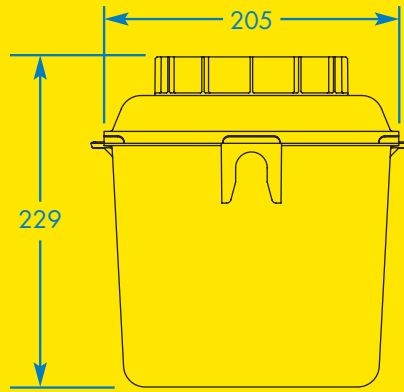

BACK VIEW

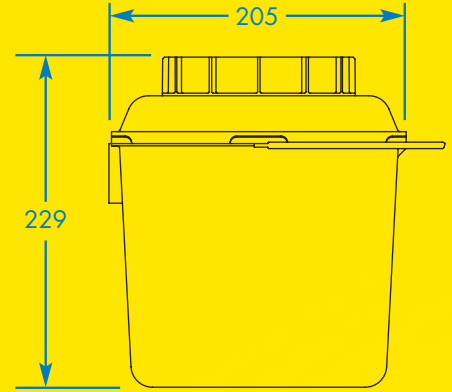

SIDE VIEW

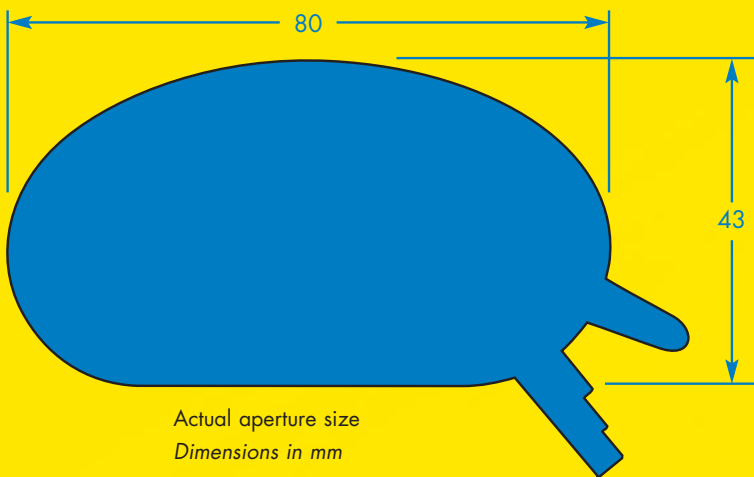

SHARPAK® 60 'PLUS' INFORMATION

Height	229 mm
Width	205 mm
Aperture	80 x 43 mm
Max Capacity	6 litres
Capacity to fill line	4.5 litres
SHARPAK 60 PLUS case re-order code	SU02600
Quantity per case	25



OPEN



1ST POSITION 'HALF OPEN'



2ND POSITION 'CLOSED'



3RD POSITION 'LOCKED'
WITH VISILOCK INDICATOR

For details regarding SHARPAK distributors and world wide availability, please contact: Amcor Flexibles/SPS Laboratoires Winterbourne Road Stoke Gifford BRISTOL BS34 6PT
Tel +44 (0)117 983 6003
Fax +44 (0)117 983 6001
E mail david.scarrow@amcor-flexibles.com
www.sharpakforsharps.co.uk