



Sharpak 220 PLUS sharps container with **VisiLOCK™** PATENTED

The Sharpak® 220 PLUS was developed following many hours of customer and market research as well as over fifteen years experience gained in the market supplying infection control products to the healthcare sector.

The SHARPAK 220 PLUS is approved to the British Standard BS7320:1990 and tested and certified in accordance with the provisions of the United Nations recommendations on the Transportation of Dangerous Goods, Chapter 9, UN3291 Clinical Waste, Unspecified, NOS.

The SHARPAK 220 PLUS offers the following features:

MANUFACTURING AND TESTED TO BS7320:1990

UN TESTED AND CERTIFIED

QUICK AND EASY TO ASSEMBLE

EASY TO OPERATE ROTATING OPEN/CLOSE/LOCK
CLOSURE

SECURE CLOSURE LOCK

FEATURING VISILOCK INDICATOR SYSTEM

DISTINCTIVE COLOURING AND CLEAR LABELLING

ONE PIECE BASE AND HANDLE MouldING

TOUGH AND DURABLE

SEQUENTIAL NUMBERING FOR TRACEABILITY

COST EFFECTIVE

PURPOSE DESIGNED BRACKET FEATURE FOR SIMPLE

WALL AND TROLLEY MOUNTING

The French Standard NF X 30-500 is only applicable to sharps containers with fill line capacity from 0.51 to 10 litres - therefore the Sharpak 220 PLUS is outside this standard.



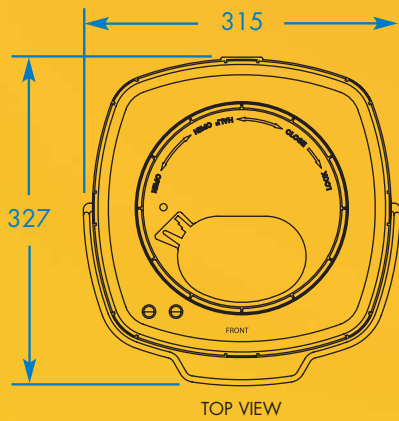

TOP VIEW

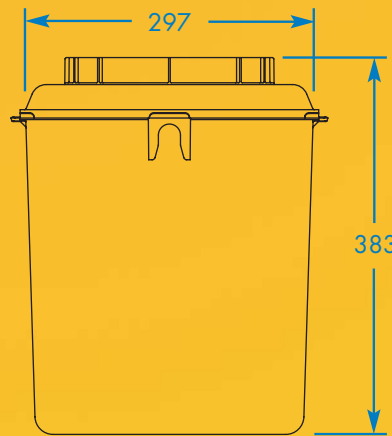

BACK VIEW

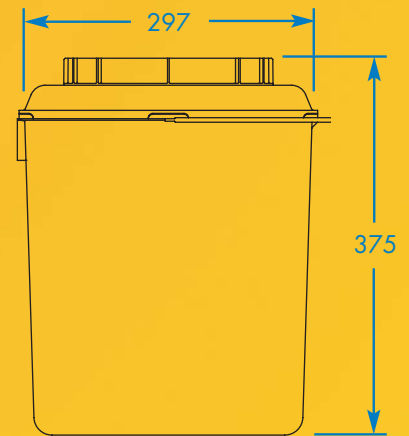

SIDE VIEW

SHARPAK® 220 PLUS INFORMATION

Height	383 mm
Width	297 mm
Aperture	85.5 x 127 mm
Max Capacity	22 litres
Capacity to fill line	17.6 litres
SHARPAK 220 PLUS case re-order code	SU02400
Quantity per case	8

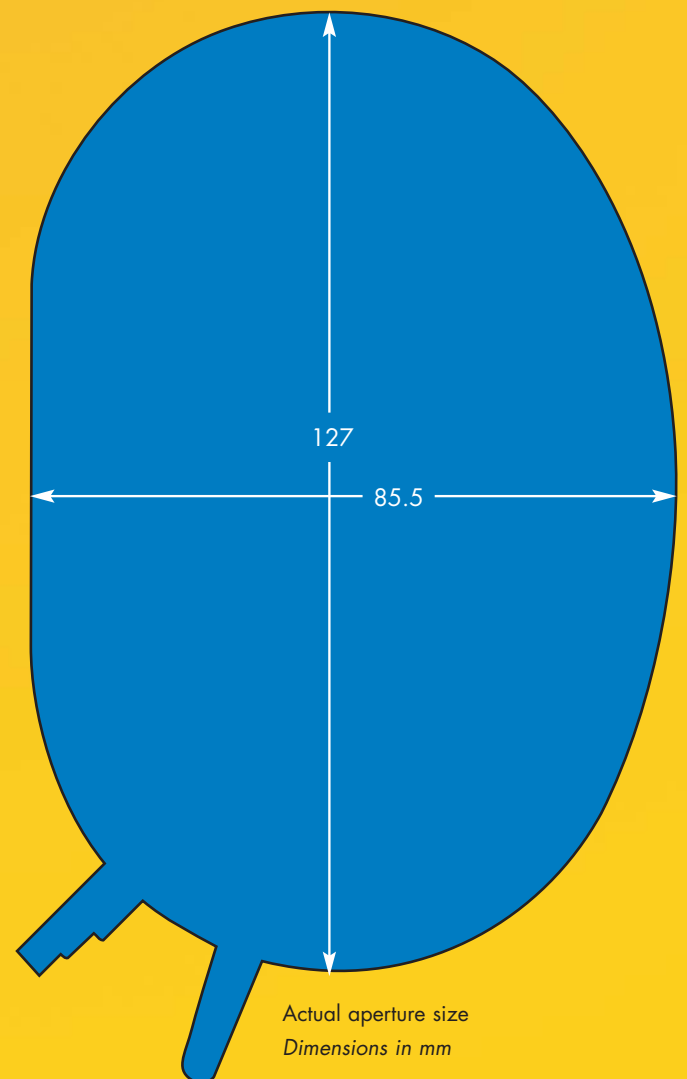

OPEN



1ST POSITION 'HALF OPEN'



2ND POSITION 'CLOSED'



3RD POSITION 'LOCKED' WITH VISILOCK INDICATOR

For details regarding SHARPAK distributors and world wide availability, please contact: Amcor Flexibles/SPS Laboratoires Winterbourne Road Stoke Gifford BRISTOL BS34 6PT
Tel +44 (0)117 983 6003
Fax +44 (0)117 983 6001
E mail david.scarrow@amcor-flexibles.com
www.sharpakforsharps.co.uk