



## The new wall mounted sharps container holder

# Now there's a solution for secure disposal

Every day of the week, at any time, people need to use disposable syringes to administer medication. This self-treatment results in the problem of what to do with used sharps.

Sharpak Healthcare has developed a wall mounted lockable secure container. The SHARPAK® *Safe & Sound* unit can be quickly and easily fixed to a wall in public toilets and rest rooms in locations such as Motorway Services, Railway and Bus Stations, Airports, Shopping Centres, Department Stores, Hospitals, A+E Departments, Ferries, and in fact, any place where public could find themselves needing a safe way to dispose of a used syringe and needle.

SHARPAK *Safe & Sound* is fitted with a lock which retains the key when the front panel is in the open position during container replacement.

The SHARPAK *Safe & Sound* features:

---

USED SHARPS KEPT SAFE FOR COLLECTION & DISPOSAL

---

DISPOSABLE BS & UN TYPE APPROVED SHARPS CONTAINER

---

SIMPLE AND QUICK TO FIX TO ANY VERTICAL SURFACE

---

LOCKABLE FRONT PANEL

---

POWDER COATED FINISH FOR LONG LIFE

---

COST EFFECTIVE

---

CAN BE SUPPLIED IN COMPANY OWN LABEL\*

---

UNITS TO ACCEPT SHARPAK 18 AND  
SHARPAK 60 PLUS CONTAINERS

\*Subject to the quantity, the SHARPAK *Safe & Sound* wall unit can be supplied finished with your company logo and contact telephone number as well as being painted to match your corporate colours.

**REMEMBER! KEEP USED SHARPS SAFE AND SOUND**

**SHARPAK**<sup>TM</sup>  
HEALTHCARE



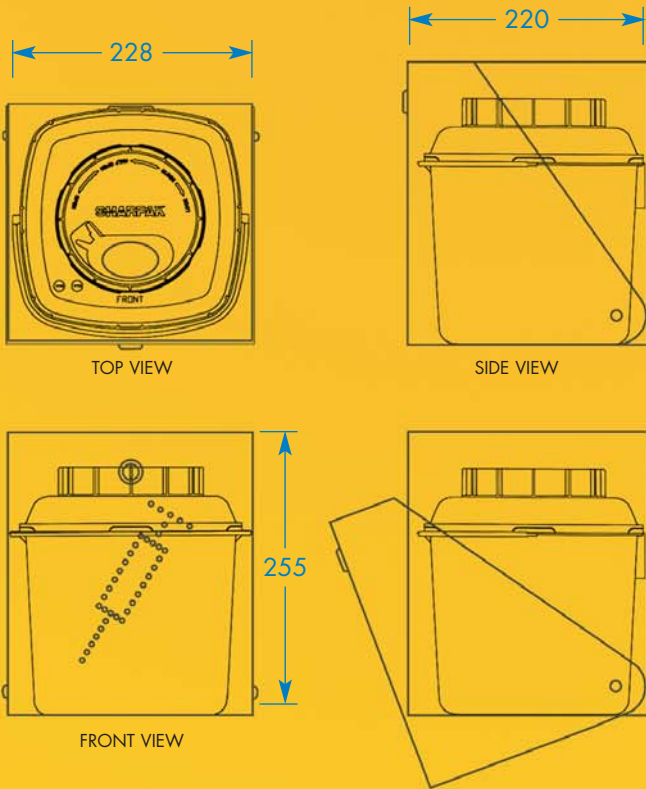

**SHARPAK 60 PLUS SAFE & SOUND WALL UNIT**

Dimensions h x w x d	255 x 228 x 220mm
Aperture	51 x 34mm
Re-order code	SS00060

**REPLACEMENT SHARPS CONTAINER**

Sharpak 60 Plus case re-order code	SU02600
Maximum capacity	6 litres
Capacity to fill line	4.5 litres
Quantity per case	25

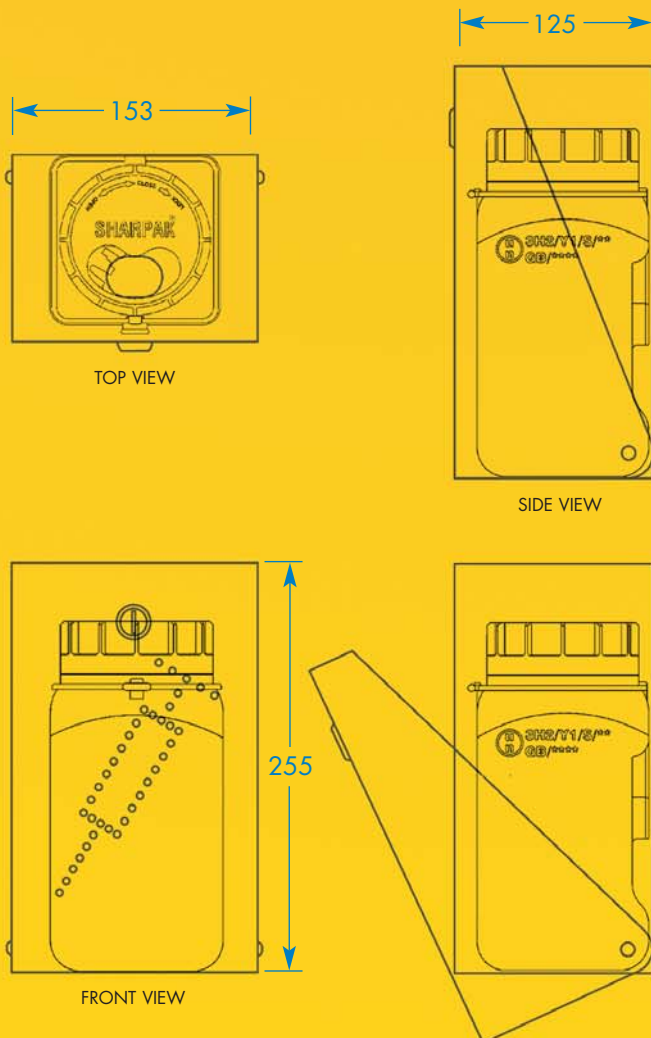
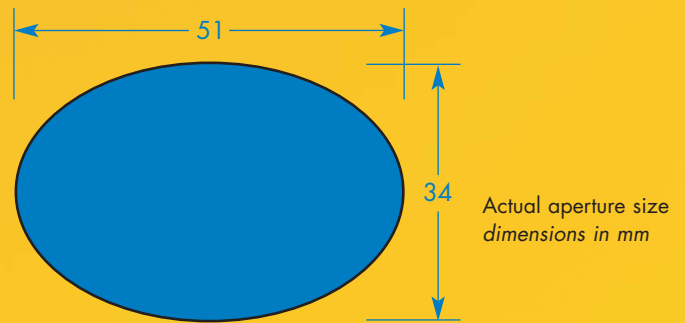

**SHARPAK 18 SAFE & SOUND WALL UNIT**

Dimensions h x w x d	255 x 153 x 125mm
Aperture	35 x 26mm
Product code	SS00018

**REPLACEMENT SHARPS CONTAINER**

Sharpak 18 case order no.	SU06495
Maximum capacity	1.58 litres
Capacity to fill line	1.27 litres
Quantity per case	48

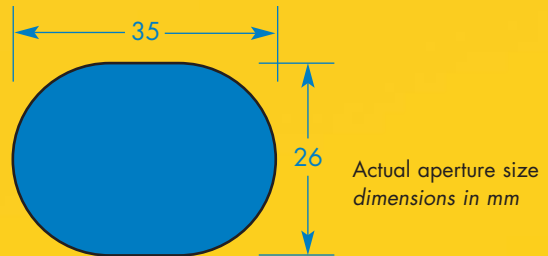

For details regarding SHARPAK distributors and world wide availability, please contact: Amcor Flexibles/SPS Laboratoires  
Winterbourne Road Stoke Gifford BRISTOL BS34 6PT  
Tel +44 (0)117 983 6003  
Fax +44 (0)117 983 6001  
E mail david.scarrow@amcor-flexibles.com  
www.sharpakforsharps.co.uk